

SECTION A-A  
SCALE 1 / 3

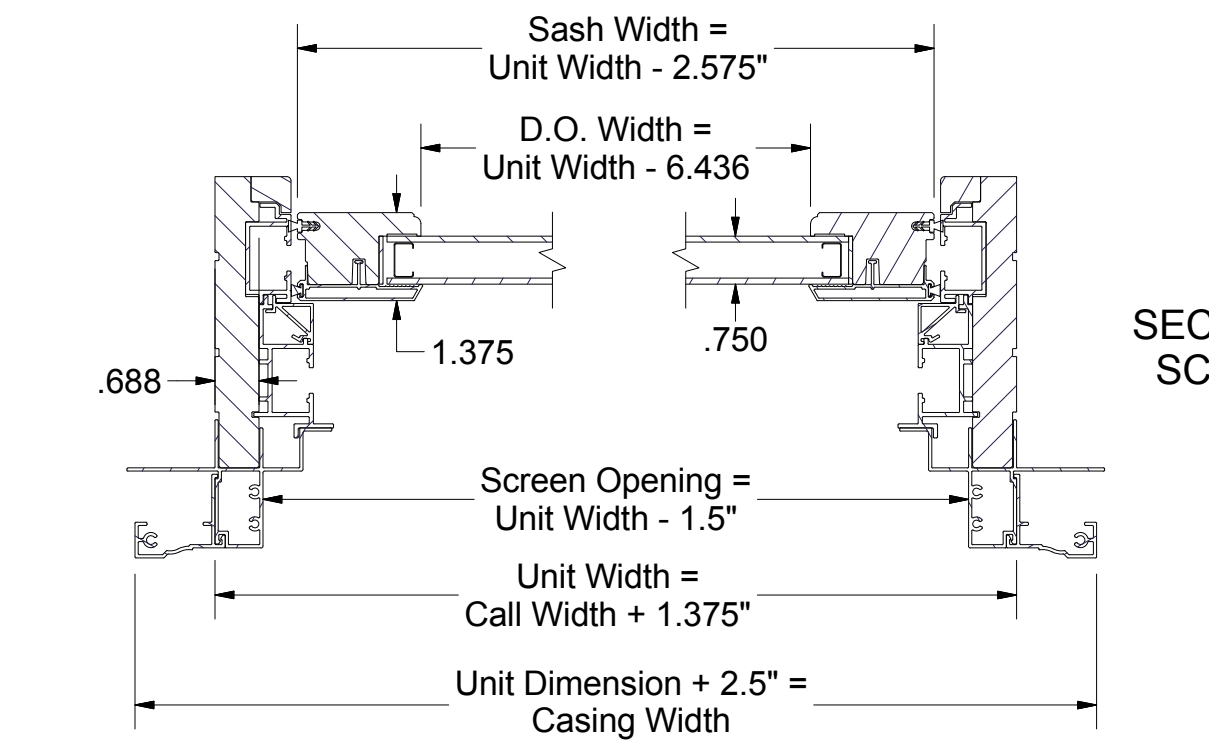

SECTION B-B  
SCALE 1 / 3

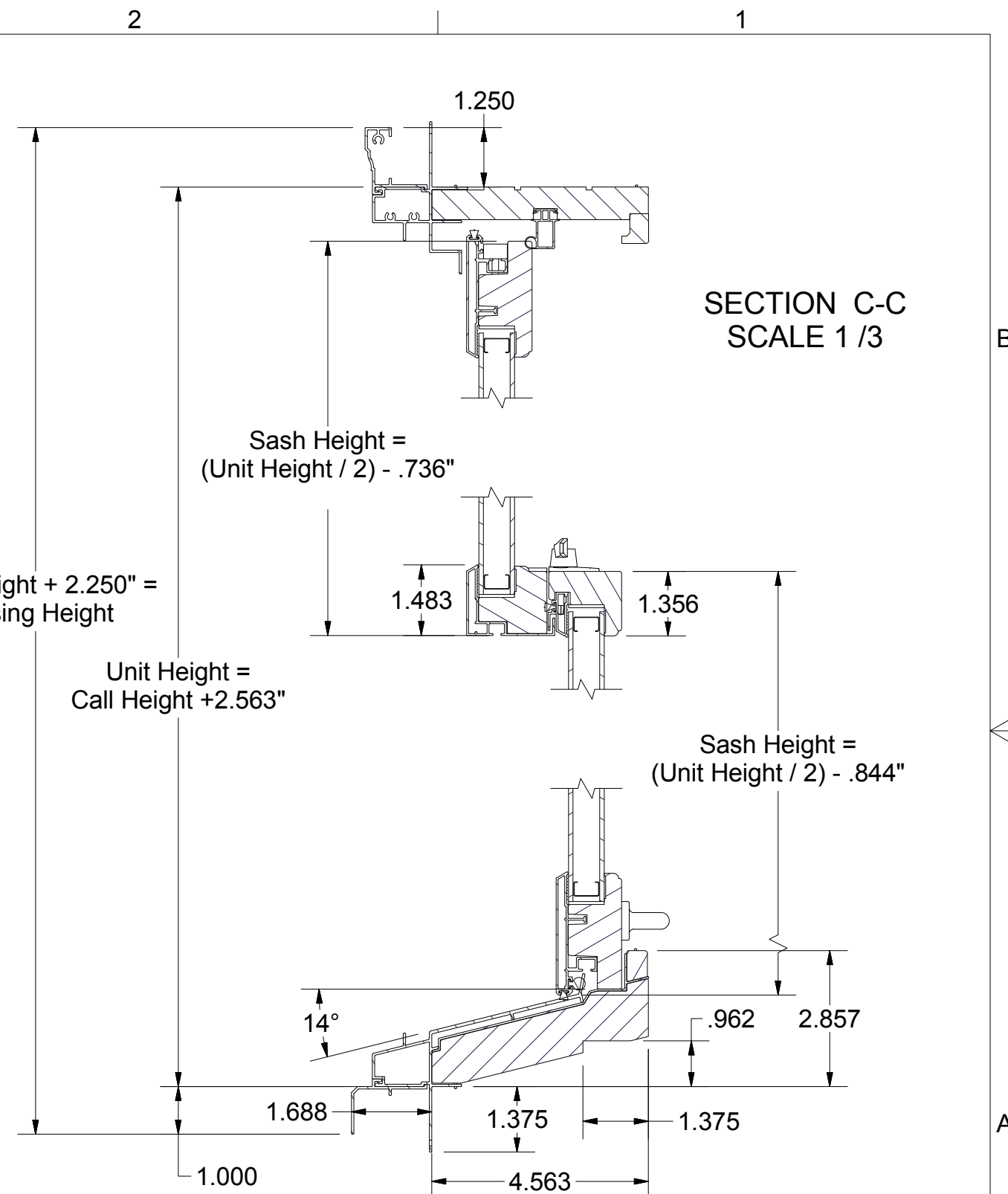

SECTION C-C  
SCALE 1 / 3

B

B

A

A

A

A

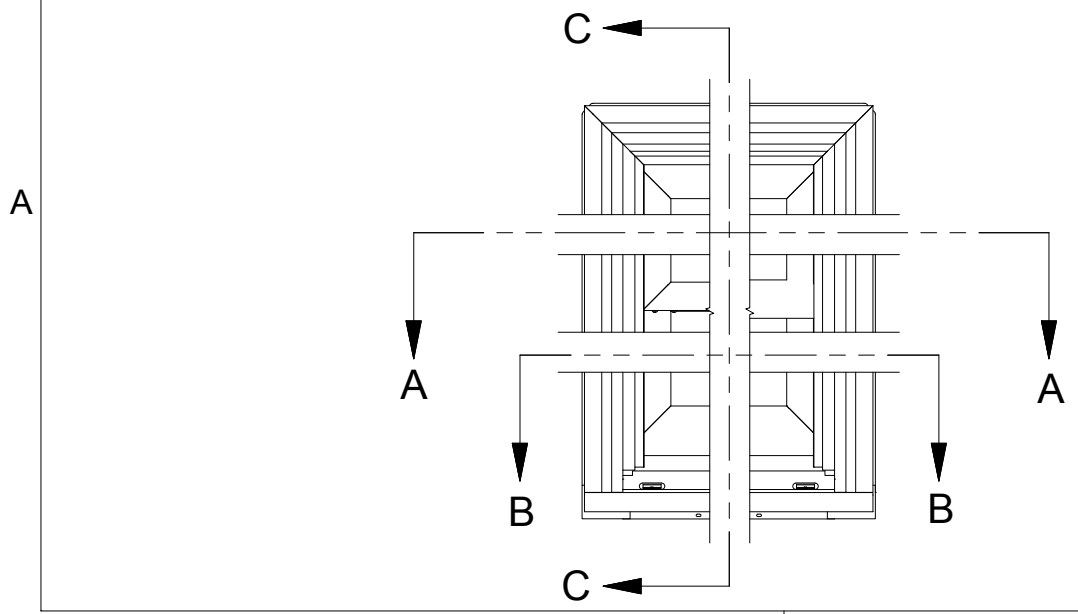

See Technical Data Sheet for standard sizes, rough openings, and other dimensions.



Tolerances Unless Otherwise Specified. All Dimensions originate at sharp corners unless indicated.  
 X.XXX ± 0.005, X.XX ± 0.015  
 FRACTIONAL ± 1/64"  
 ANGLES ± 1.0°  
 FLATNESS ± 0.020 per ft.  
 NOTE: BOXED/CIRCLED DIMS ARE CRITICAL

The information contained herein is PROPRIETARY to and considered a TRADE SECRET of Ply Gem Window Group, a Roanoke, VA based firm, and shall not be reproduced in whole or in part without the written authorization of Ply Gem Window Group.

A	NA	Initial Release	1-05-09	SAS	
REV.	ECO	REVISION	DATE	BY	

DWG. FILE NAME: EMRDH1002.idw		
SCALE:	DRAWN BY: sstrachan	REV.
SHEET SIZE: B	DATE: 4/11/2008	A
DESCRIPTION: Cross-Section, Double Hung, Brickmould Casing		