

4

3

2

1

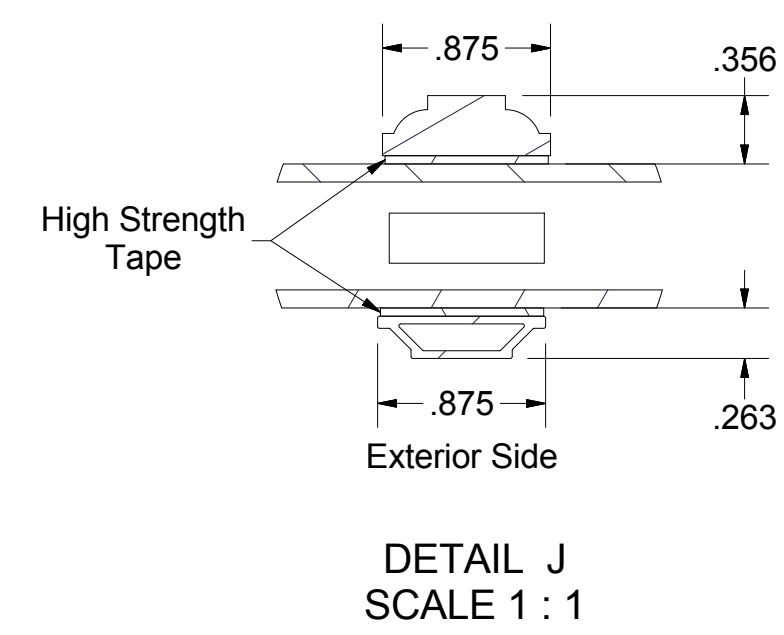
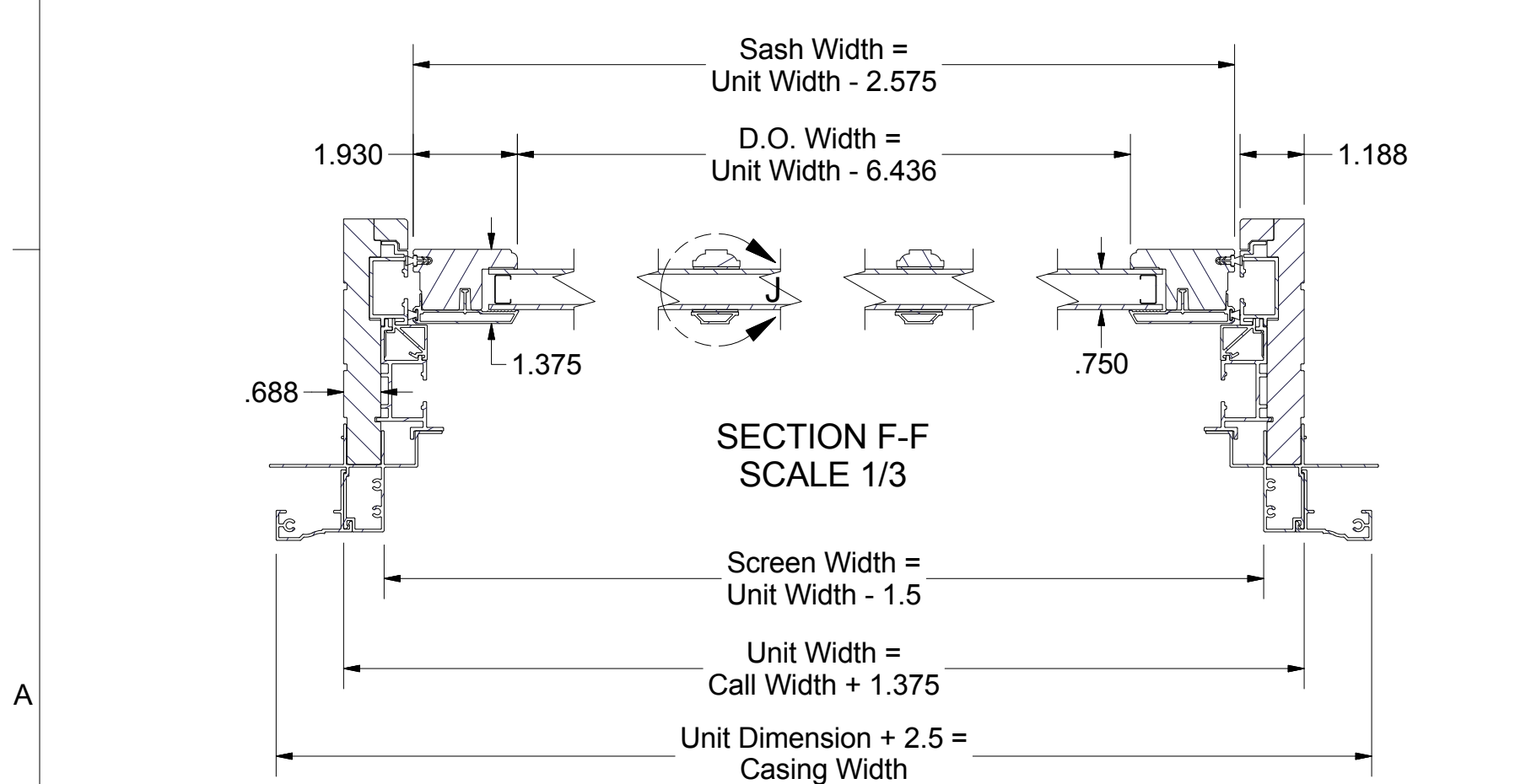
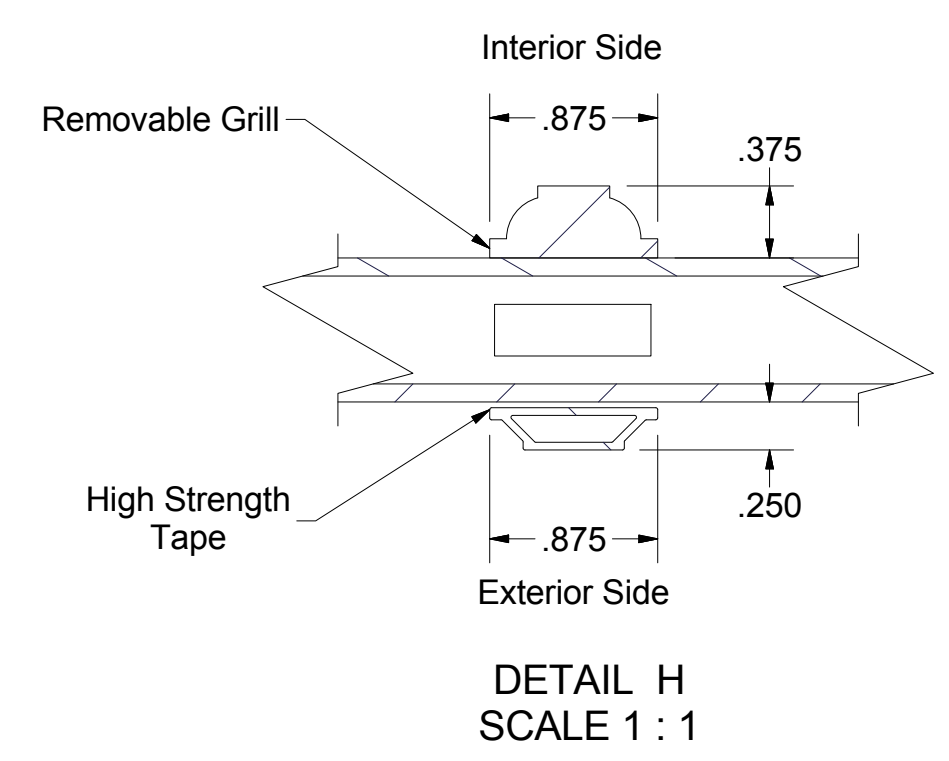
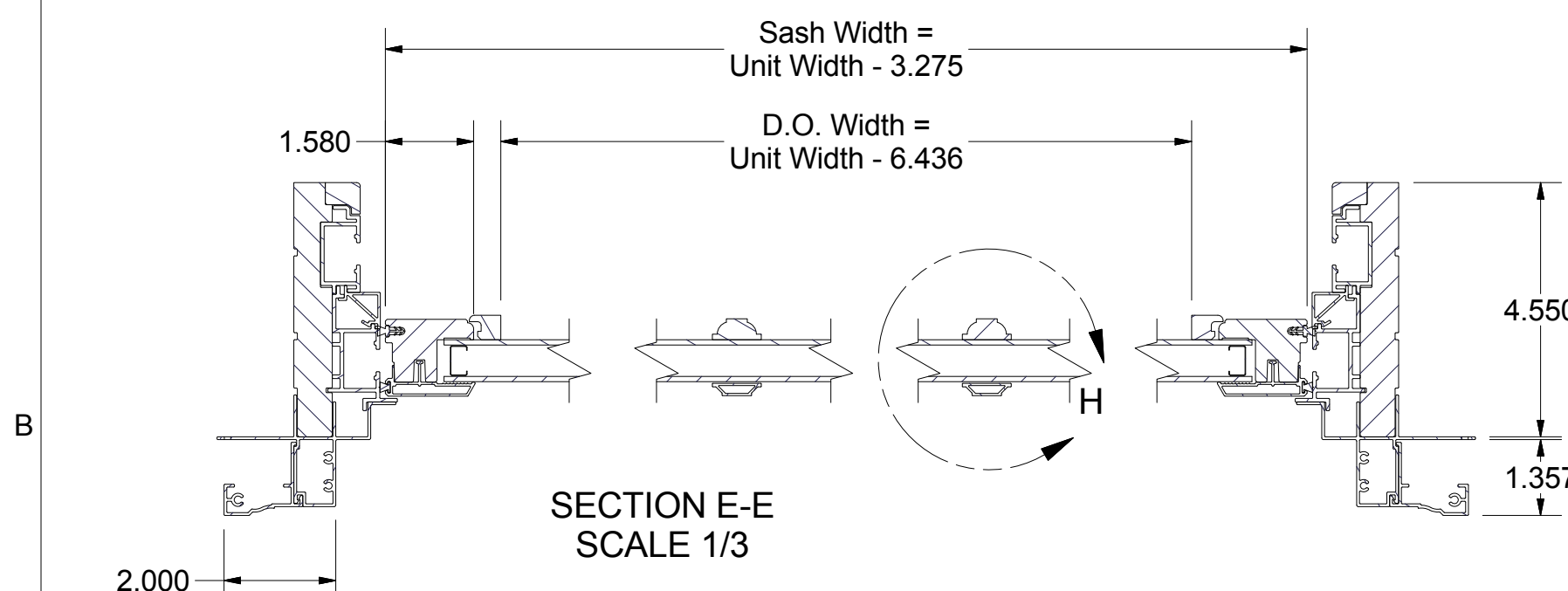
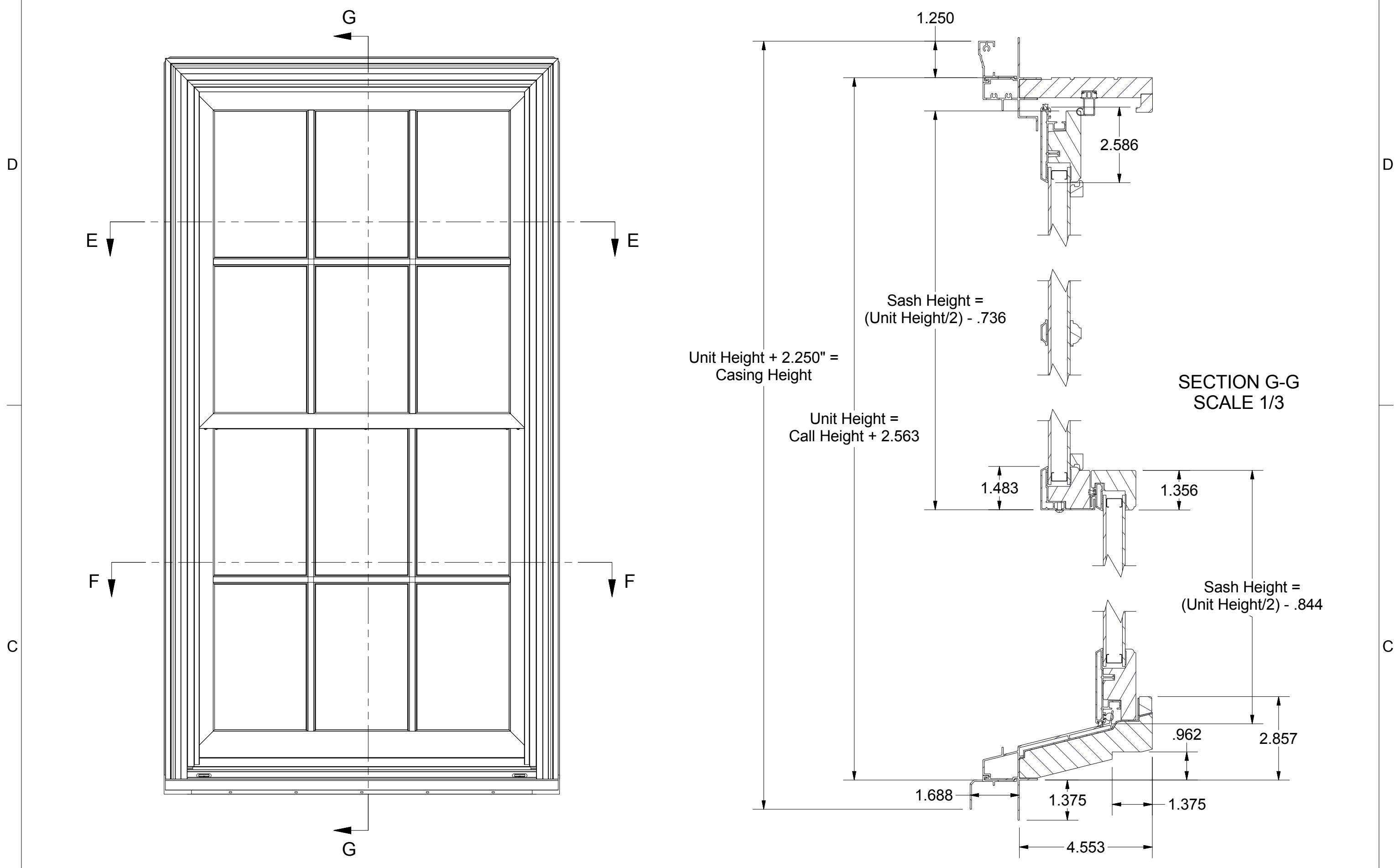

See Technical Data Sheet for standard sizes, rough openings, and other dimensions.



Tolerances Unless Otherwise Specified. All Dimensions originate at sharp corners unless indicated.

X,XXX ± 0.005, X,XX ± 0.015

FRACTIONAL ± 1/64"

ANGLES ± 1.0°

FLATNESS ± 0.020 per ft.

NOTE: BOXED/CIRCLED DIMS ARE CRITICAL

The information contained herein is PROPRIETARY to and considered a TRADE SECRET of Ply Gem Window Group, a Roanoke, VA based firm, and shall not be reproduced in whole or in part without the written authorization of Ply Gem Window Group.

DWG. FILE NAME: EMRDH1006.idw				
SCALE:	DRAWN BY: gterrell	REV.		
SHEET SIZE: C	DATE: 4/11/2008	A		
DESCRIPTION: Cross-Section, Double Hung with SDL				
REV. A	N/A	Initial Release	10/4/16	GLT
ECO	REVISION	DATE	BY	

4

3

2

1