

4

3

2

1



SECTION C-C
SCALE .09

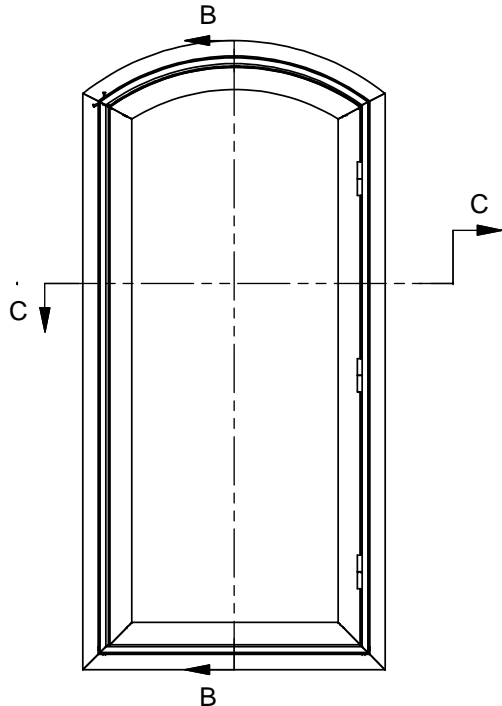

ARCH

Operating Unit
Max Width 36.000
Max Height 84.250

Stationary Unit
Max. Width 36.000
Max Height 90.000

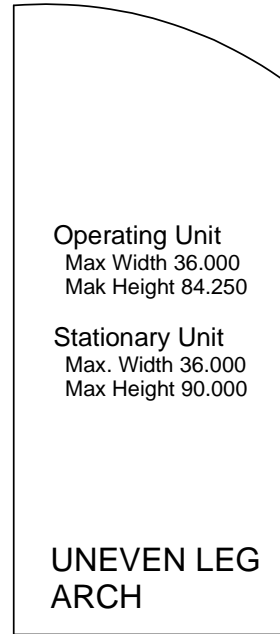

Operating Unit
Max Width 36.000
Max Height 84.250

Stationary Unit
Max. Width 36.000
Max Height 90.000

**UNEVEN LEG
ARCH**

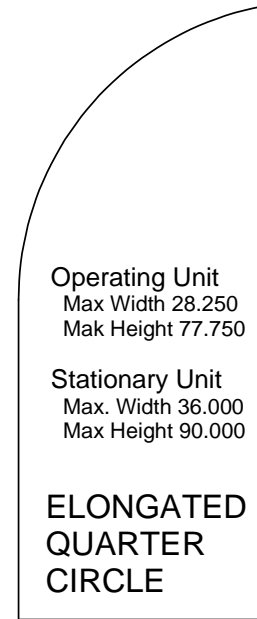

Operating Unit
Max Width 28.250
Max Height 77.750

Stationary Unit
Max. Width 36.000
Max Height 90.000

**ELONGATED
QUARTER
CIRCLE**

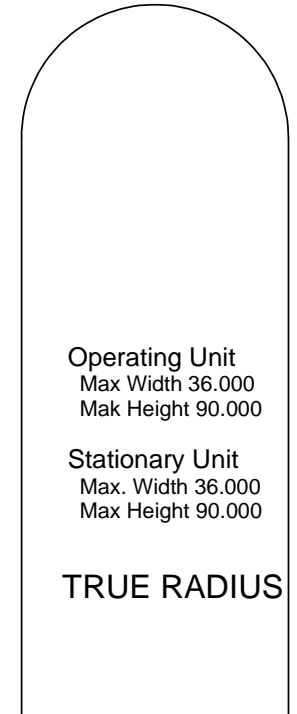

Operating Unit
Max Width 36.000
Max Height 90.000

Stationary Unit
Max. Width 36.000
Max Height 90.000

TRUE RADIUS



Tolerances Unless Otherwise Specified. All Dimensions originate at sharp corners unless indicated.
X.XXX ± 0.005, X.XX ± 0.015
FRACTIONAL ± 1/64"
ANGLES ± 1.0°
FLATNESS ± 0.020 per ft.
NOTE: BOXED/CIRCLED DIMS ARE CRITICAL

The information contained herein is PROPRIETARY to and considered a TRADE SECRET of Ply Gem Window Group, a Roanoke, VA based firm, and shall not be reproduced in whole or in part without the written authorization of Ply Gem Window Group.

DWG. FILE NAME:		
EMRICA0AH1000.idw		
SCALE:	DRAWN BY:	REV.
	rhall	
SHEET SIZE:	DATE:	
B	10/5/2010	A
DESCRIPTION:		

A	10-192	Initial Release	10-5-10	RLH
REV.	ECO	REVISION	DATE	BY

Impact, Radius Top Casement, Section View

4

3

2

1